



ACCESS
WINDOW AND DOOR
— DESIGN CENTRE —

Installation Instructions

General

Things to know before you begin

Access Windows and Doors

Access windows and doors are extremely high-quality, high-performance products built with European profiles and hardware. As these types of products are relatively rare in the North American market please read these instructions with care. Access Windows and Doors has proven these techniques with our installations in Manitoba, where these products see some of the most extreme ranges of temperature and humidity on the planet.

Mounting Flanges

If your windows and doors are equipped with mounting flanges these are intended as an aid to integrating the windows and doors with the building's water control layer. These flanges are not sufficiently strong to handles typical weights of 45 kg (100 lbs.) or more. It is neither necessary nor desirable to fasten these flanges to the building's sheathing. Also, be aware that if the wall has any twist or warp to it this can be transferred to the window or door if the flange is forced to have full contact with the wall.

Exterior Finishes and Access Windows and Doors

Different material on the exterior of a building expands and contracts due to variations in weather. Wood expands and contracts based on humidity. Plastics such as PVC expand and contract with temperature. As Access windows and doors are primarily fiberglass, they have considerably less expansion and contraction than PVC. Because of these varying rates of expansion and contraction, leave enough spacer around the windows and any exterior finishes to assure no loads get placed on the windows.

Interface with Building Envelope

Following these instructions will ensure a sound structural installation of your windows and doors. As Access Windows and Doors provides fenestration for a large variety of high-performance walls, Access cannot provide details for integration with a building's water, moisture, and air control layers. Access recommends that the guidelines found in the InstallationMastersTM Training Manual¹ or provided (mostly at no cost) by Building Science Corporation, buildingscience.com. Access Windows and Doors is not liable for damages due to improper installation.

In almost all cases, Access Windows and Doors recommends a sill pan flashing be installed before the window. This flashing offers an extra layer of water protection should there be imperfections in the interface between the window and the water control layer of the building.

Material Compatibility

Access window and door profiles have a core of fiberglass with a 1mm thick PVC cap. Colored profiles have an additional (primarily acrylic) laminate. Ensure all sealants and materials are compatible with PVC

1 © 2008 InstallationMastersTM Institute, 1827 Walden Office Square, Suite 550, Schaumburg, IL 60173, www.installationmastersusa.com

Protective Tape and Films

Often windows will be shipped with protective tape over the frame components. At times glass may be shipped with a protective film. These tapes and films must be removed immediately after installation. Failure to do so and continued exposure to UV and temperature swings may result in tapes and film being nearly impossible to remove.

Tools and Materials Required

Table 1: Tools needed



Spirit Levels	Short spirit level for small openings and longer levels. Access recommends using the longest possible level that is usable.
Framing hammer	
Tape measure	
Screw gun	
Screwdriver	
Flat pry bar	
Caulk gun	
Vacuum cups 	A minimum of two vacuum cups are recommended for handling large, heavy windows and doors.
Metric hex key set	Used for any necessary adjustments.

Table 2: Materials not supplied by Access

Fasteners for anchor straps (one per strap)	Wood: #10 x 1 ½" pan head screws Concrete: #10 x 1 ¼" suitable for concrete (e.g. Spax Multimaterial, Tapconn) Steel studs: #10 x ¾" suitable for steel pan head All screws need to be selected for corrosion resistance against the substrate they are being used in.
Sealants and flashing tape	Suitable sealants, perimeter insulation, and flashing tapes for integrating the window in the building envelope. All materials must be compatible with PVC and each other.
Shims 	Plastic or other non-deteriorating dimensionally stable material, minimum 1 ¼" x 1 ½".

Correct: cups avoid joint and edges

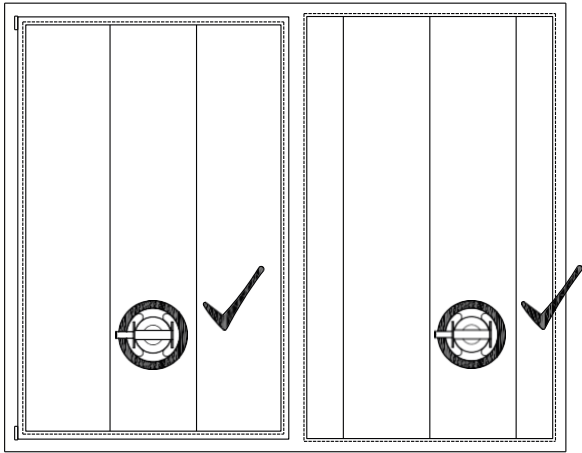

Incorrect: cups on joint and edges

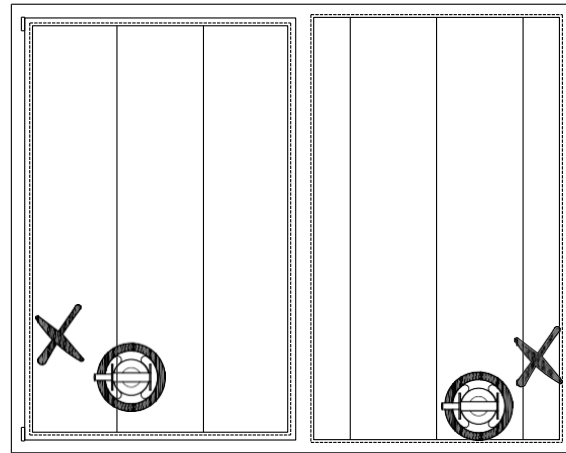

Table 3: Materials shipped with windows and doors

Installation straps	Straps will be in one or more cardboard boxes shipped with the windows.
Handles	
Lock Cylinders and Keys	
Screen Clips	
Screens	

Receiving, Inspection, Handling, and Storage

Receiving and Inspection

Please inspect the windows and doors after unloading them to ensure they were not damaged during shipping. Check for broken glass, cracked frames, and damaged finishes. If damage is found, please inform your sales representative.

Inspect each window once again before installation to ensure it has not been damaged at the jobsite.

Handling and Moving Product

Safe Handling

The installer carries the final responsibility for safely handling windows and doors, some of which can be very large and heavy. The guidelines here are to avoid damaging the windows and doors during movement.

Carrying Product

In general:

- Use two or more people to carry larger windows and doors.
- Carry windows and doors as vertically as possible.
- Product with a nailing flange will have one or more support blocks attached to protect the flange.
- Ensure that when stored the window or door is resting on the blocks.
- Do not lift frames from the top member.
- Do not bend frames to get around a corner.
- Avoid racking frames.

Frames without Glass.

Even frames with no glass can be heavy. Support the frame from the bottom at the jambs or by grasping the verticals near the corners. Lift and set down frame gently.

Frames with Glass.

Frames with glass may be carried the same as frames with no glass.

Larger units with glass may be carried with the aid of vacuum cups. Do not use cups on any glass that has a film present. Avoid the edges of glass. The best placement is towards the bottom corners of the insulated glass unit.

See Figure 1.

Partially Glazed Units.

Partially glazed units need to have the unglazed portion of the frame supported during movement. Follow the above guidelines for frames with and without glass.

Storage

In general:

- Store windows and doors indoors.
- Do not vertically stack windows where they can be exposed to direct sunlight. Solar heat can get trapped between the windows, leading to heat damage.
- If the units have a nailing flange, ensure you rest it with the support block(s) down.
- When stacking vertically, keep the bottom edge within 25cm (10") of the support. Frames may lean against one another at the same angle, but do not stack more than seven frames deep.
- Use protective padding between frames to protect finish and allow venting.
- Protect the windows from potential jobsite hazards.
- Be especially careful with windows and doors in freezing temperatures as the composite material can become more brittle.

Rough Openings

For windows, rough openings should give clearances of 13mm to 16mm (1/2" to 5/8") around the entire perimeter. If extension jamb holders from Access are used, clearance should be the full 16mm (5/8").

For doors, rough openings should give clearances of 13mm to 16mm (1/2" to 5/8" at the jambs and 19mm (3/4") at the head.

Figure 2: Clearance at window jamb

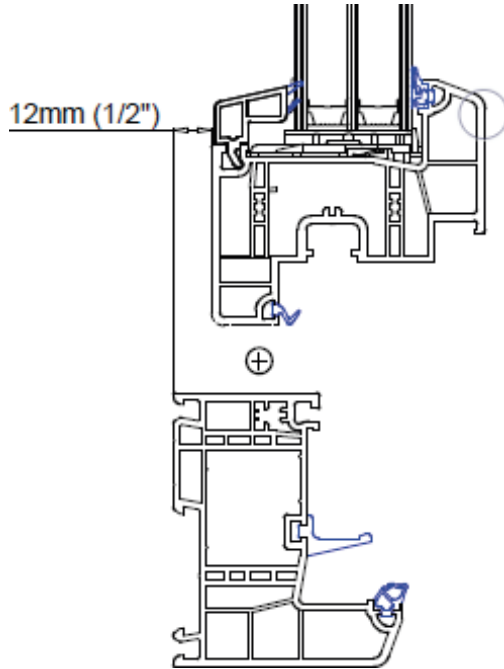

Figure 3: Clearance at door jamb

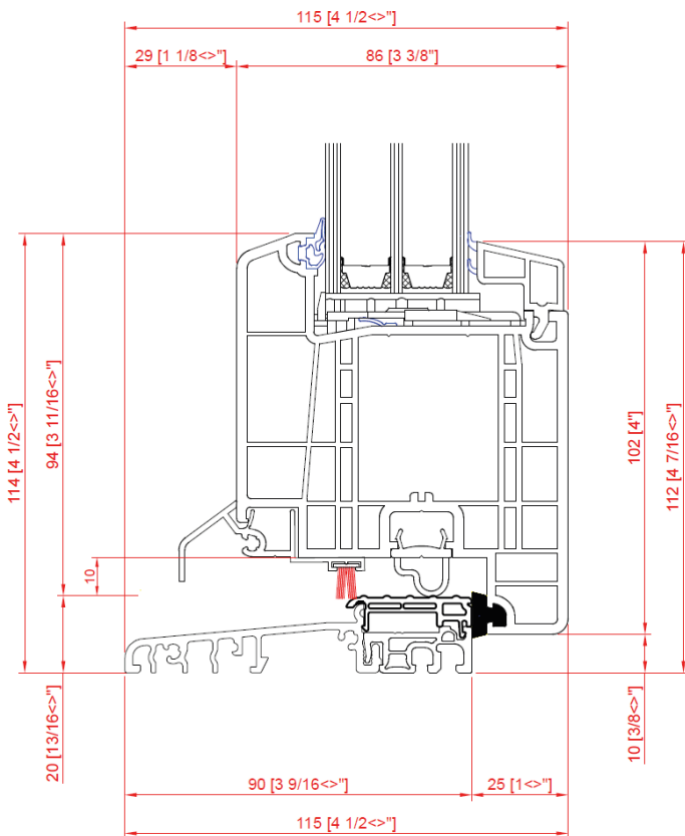
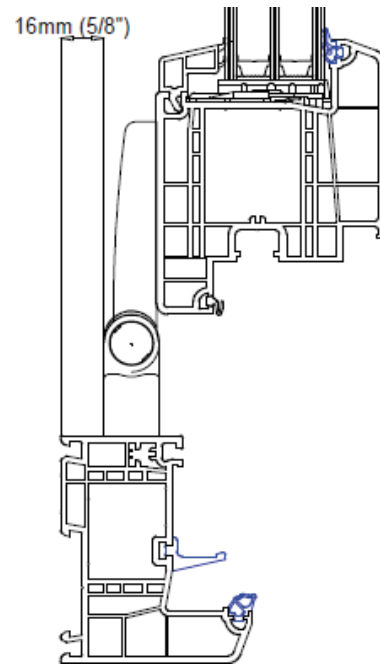

Figure 4: 20mm aluminum sill, inswing door

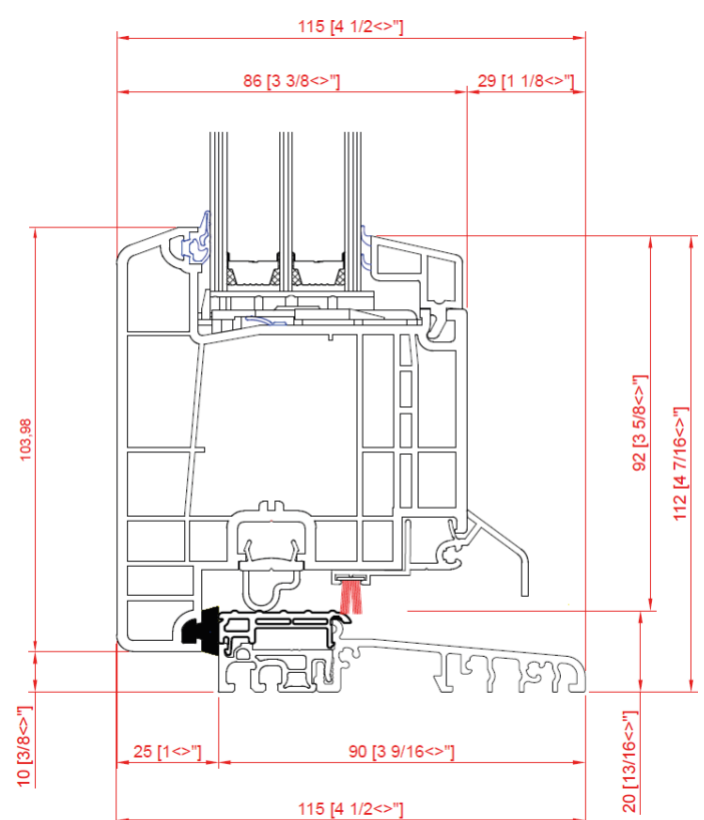

Figure 5: 20mm aluminum sill, outswing door

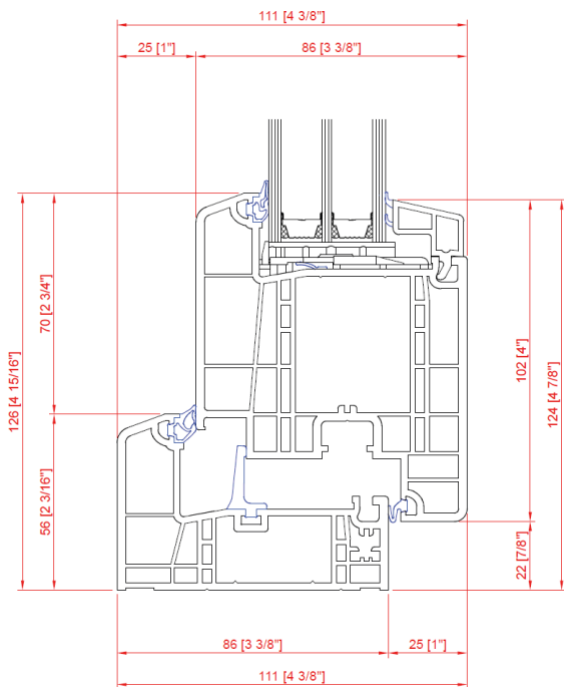

Figure 6

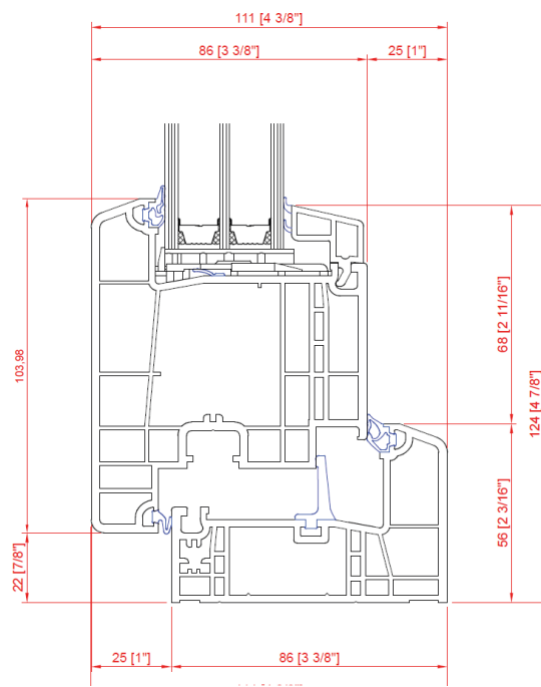

Figure 7

Window and Tilt & Turn Door Hardware Clearance

Ensure that the rough opening is sized appropriately so that any jamb extension material does not overlap the frame more than 12mm (1/2") or the window will not be able to open a full 90° (Figure 2).

Entry Door Hardware and Sash Clearance

Ensure that the rough opening is sized appropriately so that any jamb extension material does not overlap the frame more than 12mm (1/2") for adequate clearance to the hinges (Figure 3).

The aluminum door threshold only has 10mm (3/8") clearance from the bottom of the door sash to the bottom of the sill. Ensure rough openings are designed so as to give adequate clearance for any planned flooring, carpeting, rugs, etc. (Figure 4 and 5).

The 56mm high performance door sill has only 22mm (7/8") clearance from the bottom of the door sash to the bottom of the sill. Ensure rough openings are designed so as to give adequate clearance for any planned flooring, carpeting, rugs, etc. (Figure 6 and 7).

Parallel and Tilt & Glide Hardware Clearance

The maximum a floor may encroach up the sill of a tilt & glide or parallel glide door is 11mm (7/16"). Flooring beyond this height will not have room for the sash to clear any mats or rugs as the sash moves outward before sliding open (Figure 8 & 9).

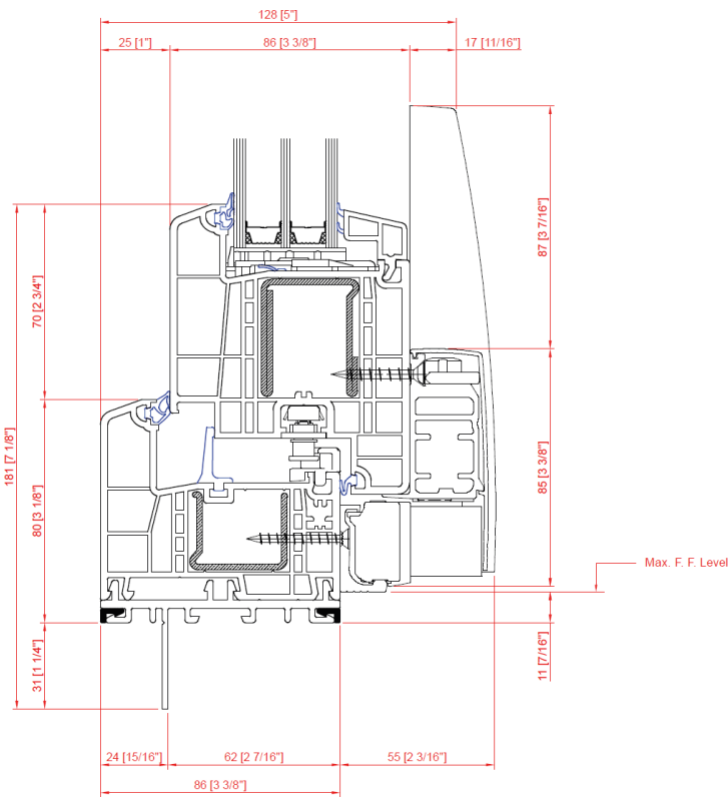

Figure 9

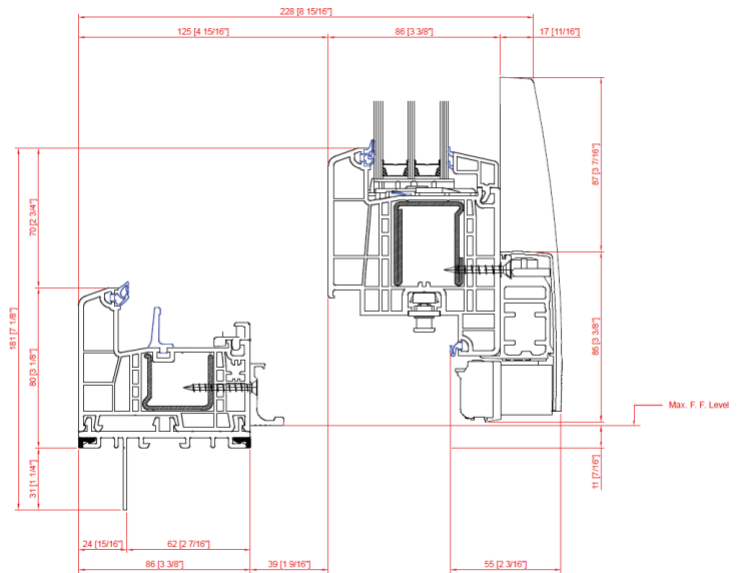

Figure 10

Preparation

The included instructions are for the standard handles supplied with Access windows and doors. If your project includes custom handle sets that have varying installation, instructions will be included with the handles.

Windows and Tilt & Turn Doors

Please reference Figure 10.

Sash is locked in frame

1. Reference Figures 11, 12 and 14.
2. Insert handle facing down in the lock position.
3. Turn handle 90° towards the glass.
4. Slightly pull out backplate and rotate 90°.
5. Insert screws. Snug the screws by hand.
6. Turn backplate to cover screws.
7. Turn handle back to lock position.

Sash shipped separately from frame

1. Reference Figures 11, 13, and 14.
2. Turn handle 90° to the turn position.
3. Insert handle in frame.
4. Slightly pull out the backplate and rotate 90°.
5. Insert screws. Snug the screws by hand.
6. Turn backplate to cover screws.

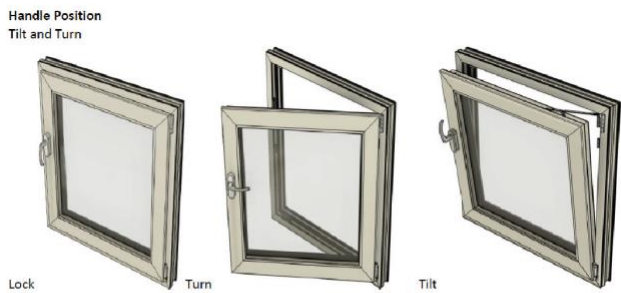

Figure 10



Figure 11: Handle with backplate

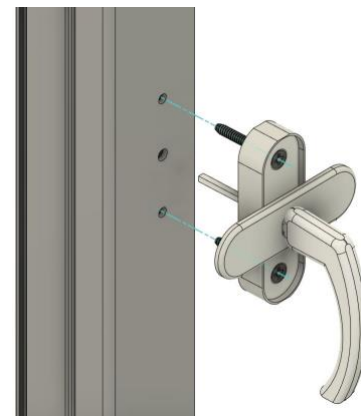

Figure 12: shaded with visible edges

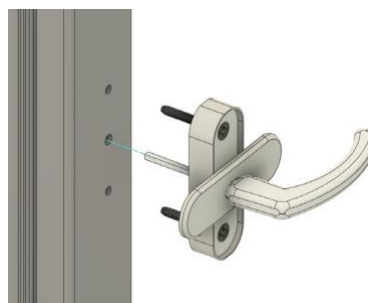

Figure 13

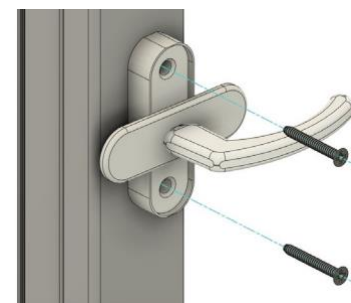

Figure 14

Entry Doors (Figures 15 & 16)

1. Be certain to place the keys in a safe location.
2. If the handle shaft is not already inserted in one of the handles, insert it.
3. Insert the gaskets into the backside of the handle backplates.
4. The side that the screws go through goes to the inside. The side the screws screw into goes to the outside. Slide the handle shaft through the topmost hole for the handle set on the sash with the handle horizontal and pointing towards the center of the door.
5. Slide the other handle and backplate (mirroring the first handle) over the protruding shaft.
6. Insert the screws and screw them in so the backplates still have some play in them.
7. Take the lock cylinder and turn the knob so the arm aligns with the body.
8. Insert the lock cylinder key side first from the inside of the door.
9. Insert the screw for the lock cylinder from the side of the sash. Wiggle the lock cylinder back and forth until you feel the screw find the hole.
10. Tighten the screw for the lock cylinder by hand. Snug it but do not overtighten.
11. Tighten the screws for the backplate by hand. Snug them but do not overtighten.



Figure 15: Entry Door Handle



Figure 16: Lock Cylinder

Remove the Sash

Windows and Tilt and Turn Doors

1. Slightly turn open the sash.
2. Remove the hinge cover (Figure 17).
3. One installer supports the weight of the sash. A second installer uses a screwdriver to begin to push the hinge pin down and out. The same tool can be used to finish pulling the pin out from below. Pull the pin until you hear a click. If you pull it all the way out reinsert until you hear a click (Figure 18).
4. Slightly tilt the sash out of the frame and lift it off the lower hinge pin (Figure 19).
5. Store the sash in a safe place on a clean and dry surface that will not mar the surface. Ensure dirt and debris cannot enter the hole of the lower sash hinge.
6. Push the pin back in until it clicks in place. Replace the hinge cover so it does not get lost.

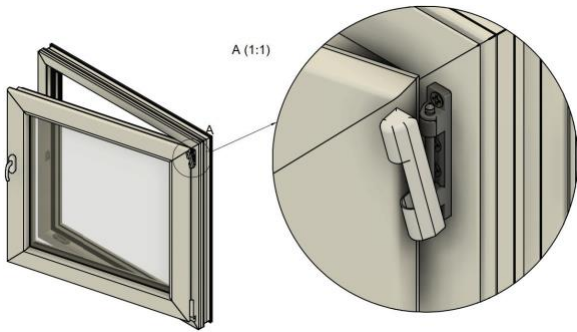

Figure 17

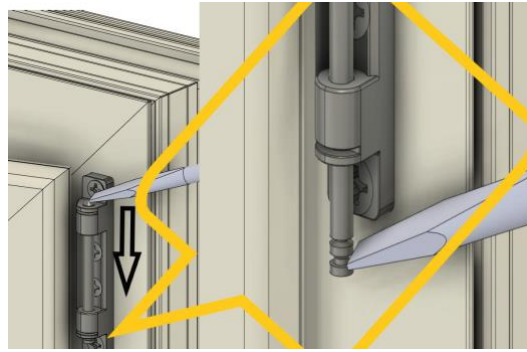

Figure 18

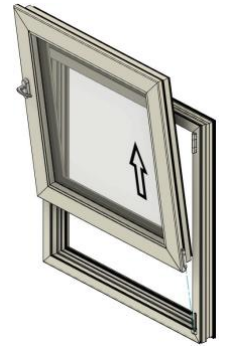

Figure 19

Entry Doors

Entry doors require a minimum of two people to remove the sash.

Access recommends suction cups for lifting the sash.

1. While one person supports the frame, turn the sash out 90°.
2. Lift the sash out of the frame portion of the hinges (Figure 20).



Hinge-side Drywall Return

Before installation, remove the drywall return on the hinge-side of the door to prevent bending or damage. Be sure to keep the drywall return in a safe place.



Figure 20

Inspect Units

1. Inspect for damage.
2. Inspect glazed units for bowing. If bowing is found it can be removed with a block of wood and a hammer (Figure 21). (Bowling is typically caused by lifting by or setting on an unsuitable location of the frame).

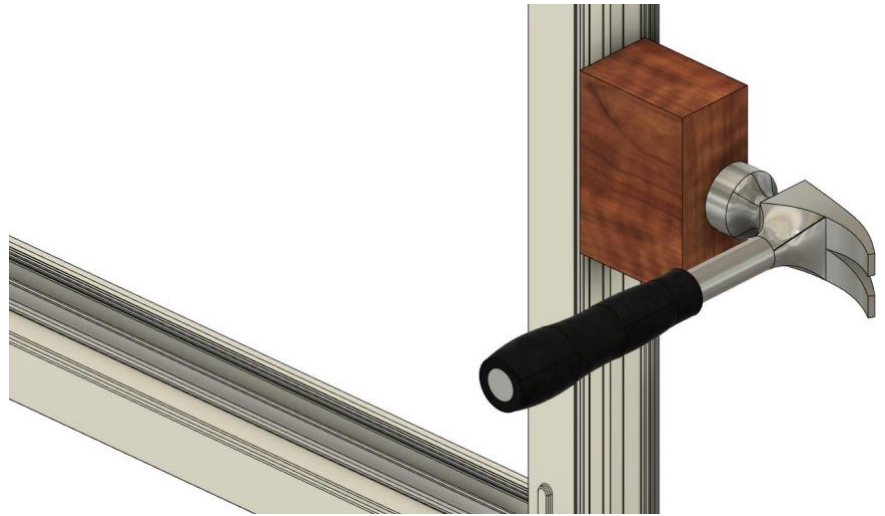

Figure 21

Install Anchor Straps

Windows

1. Anchor straps are first installed 150mm (6") from each corner. The anchor straps are installed by inserting them into the groove parallel to the frame and turning 90°. See Figure 22.
2. If there are vertical or horizontal mullions or couplings, install anchor straps 6" from each side of the mullion or coupling.
3. Add additional anchor straps as needed between the corner and mullion anchor straps. Assure that for windows under 1.4 m² (15 ft²) there is no more than 40 cm (16") between the anchors. For larger windows, ensure the spacing is no more than 30 cm (12"). Anchor straps should be spaced as evenly as possible.
4. Anchor straps should be given a slight bend towards the center of the window to prevent them from hanging up upon installation (Figure 23).

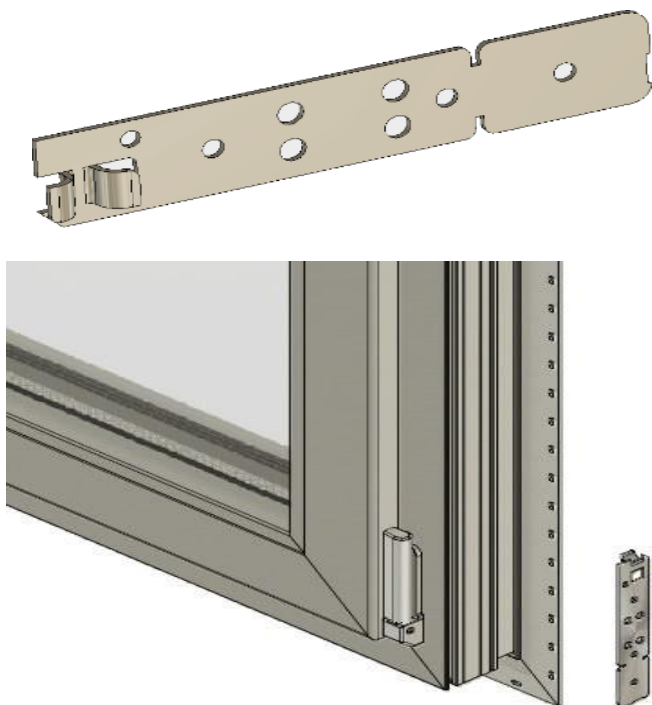

Figure 22



Figure 23

Doors

1. Anchor straps are first installed 150mm (6") from each corner. The anchor straps are installed by inserting them into the groove parallel to the frame and turning 90°. They are not applied at the sill with the exception of tilt & slide and parallel slide doors (Figure 20).
2. If there are vertical or horizontal mullions, install anchor straps 6" from each side of the mullion.
3. Add anchor straps between the corner and mullion anchor straps. Ensure the spacing is no more than 30 cm (12"). Anchor straps should be spaced as evenly as possible.

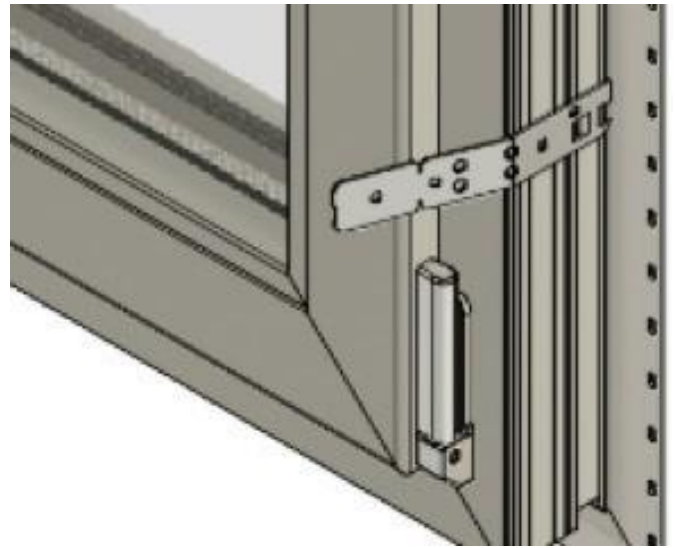

Installation

Set Shims at Sill and Insert Window

1. Set shims on both sides so the sill is level. Doors should only be shimmed off the floor where they need to be leveled. Windows should be shimmed up enough to center them in the rough opening. Tilt & turn and turn only windows should be shimmed directly under each jamb. Hopper windows (bottom hinged only) should be shimmed under each shim. Picture windows should be shimmed approximately 125mm (5") from the edge of each jamb.
2. Insert the window and check for fit.
3. Once the sill is level, add additional shims under each mullion (Figure 21), under each jamb, at any coupling (Figure 22), or as needed for additional support for very large windows and doors. Ensure the sill is not bowed either up or down.

T-Mullions

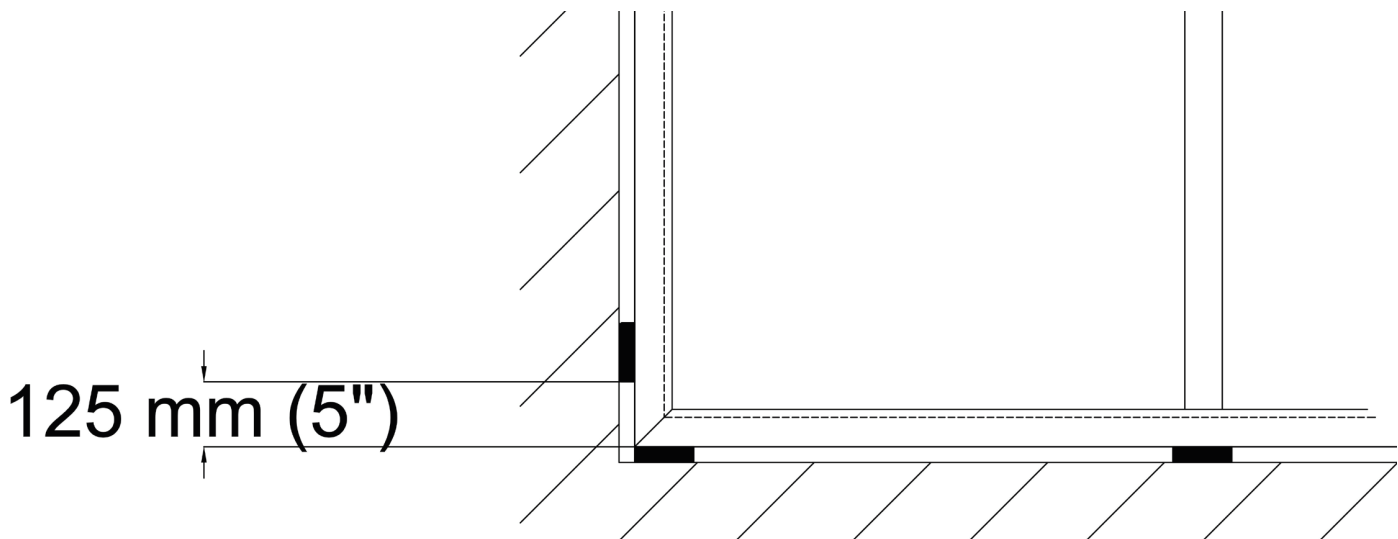

Fasten Anchor Straps

1. Pre-bend the anchor towards the window. The purpose of this is to have it sit flat against the rough opening when fastened (Figure 23).
2. Adding a compatible sealant to the side that fastens to the rough opening can aid air and water sealing later.
3. Fasten the anchor to the rough opening with a suitable fastener.

Shim Window

Windows and doors should be shimmed to the rough opening per the diagrams below. This is critical for transferring loads to the rough opening. A flat pry bar may be used to provide clearance to insert the shims.

After inserting shims, the window or door must be plumb, level, and square. If it is not, adjust the shimming.

Ensure there is no bowing in either plane. Unglazed frames can have bowing removed by adding shims or adjusting anchor straps. Glazed frames can have the bowing removed as described under "Inspection" (Figure 21).

Mulled Frames

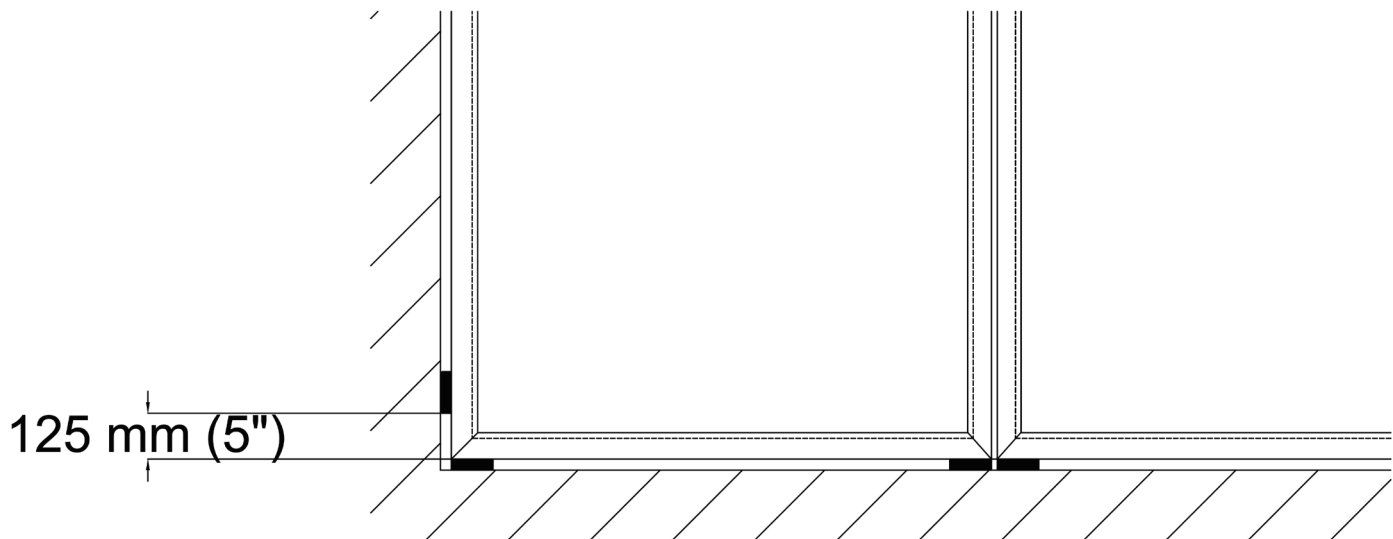

Tilt & Turn Window

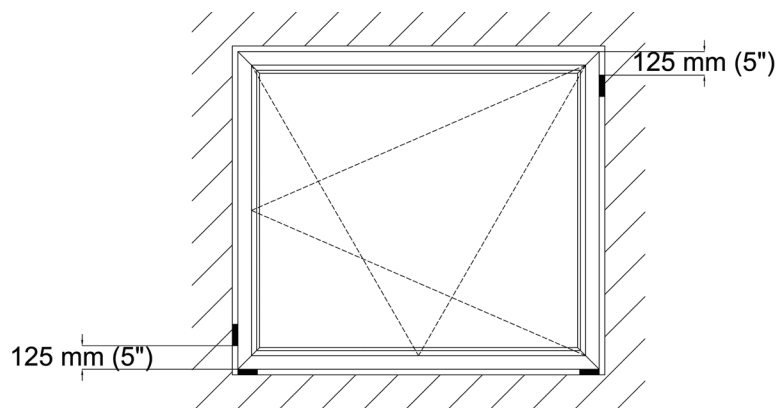

House and Balcony Doors

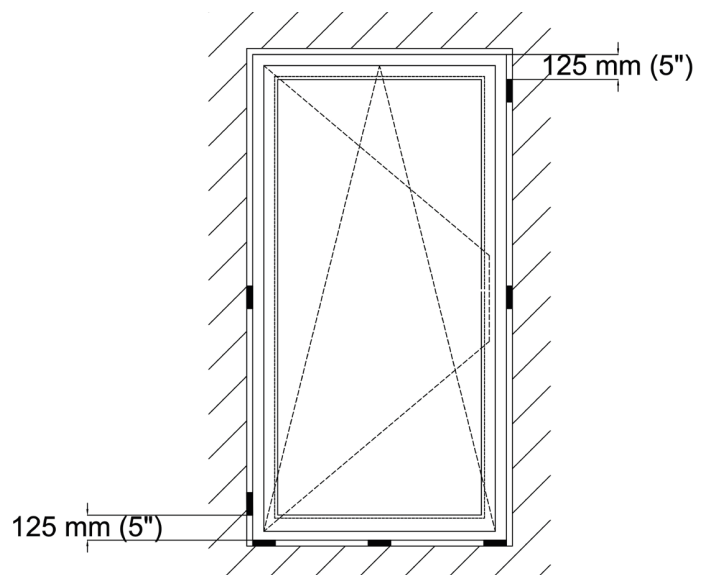

Picture Window

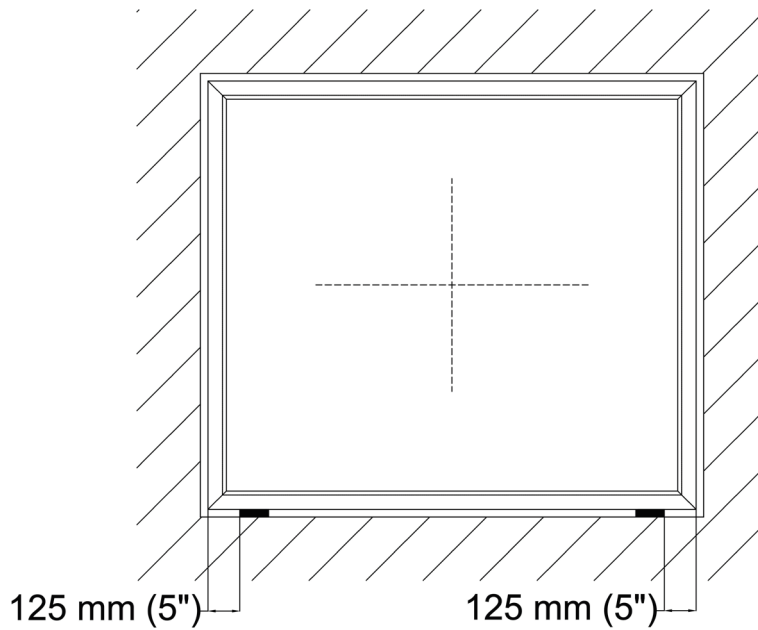

Hopper (Tilt-only) (Shims underneath the hinges)

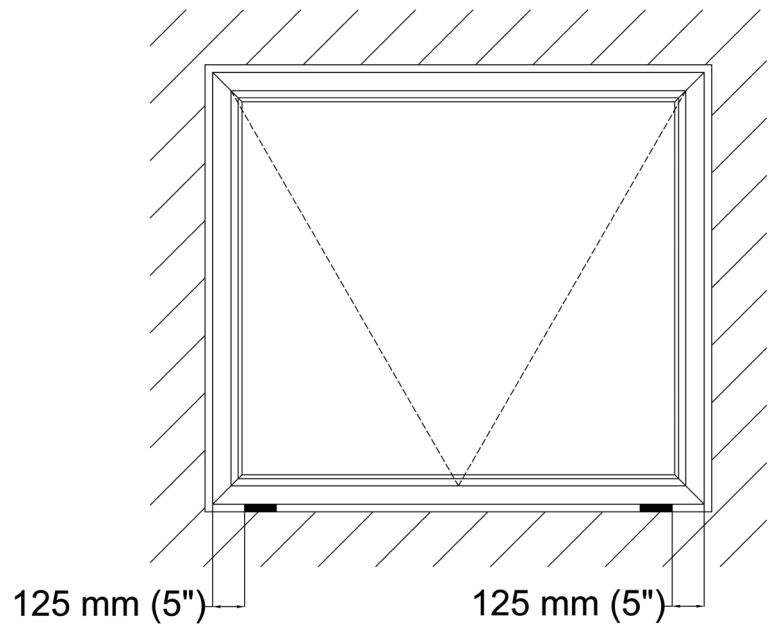

Mullion-less French Window (The shim in the area of the meeting rail should not affect operation by bowing the sill).

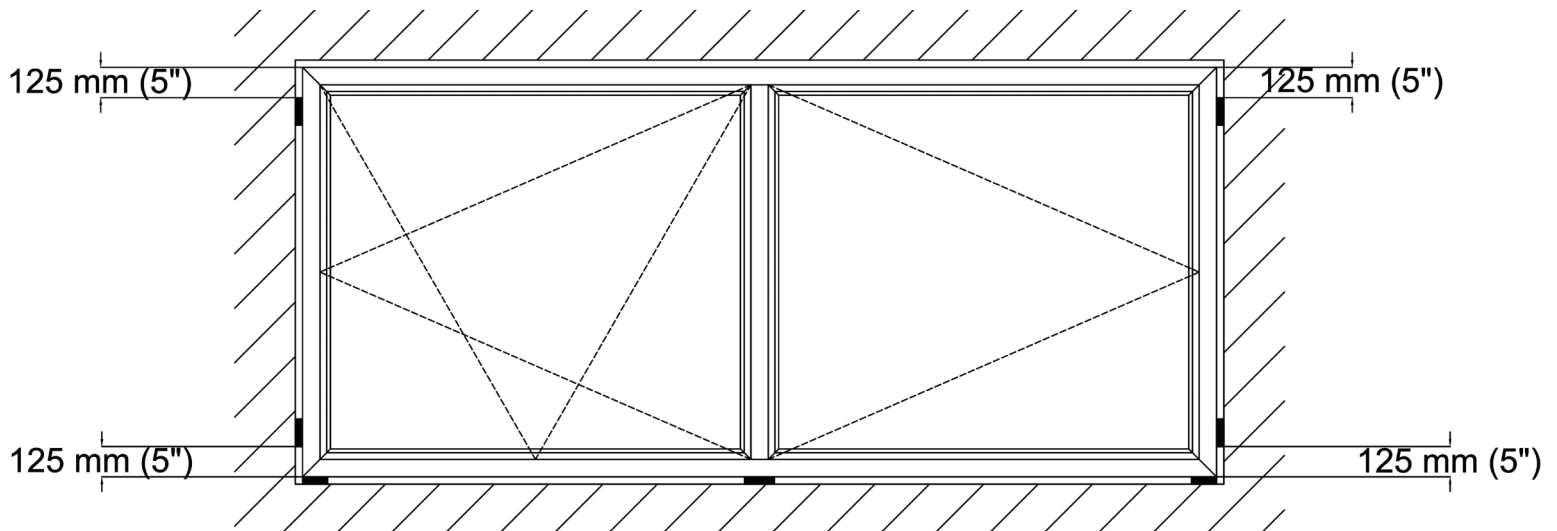

Lift and Slide, Parallel Glide and Tilt and Glide

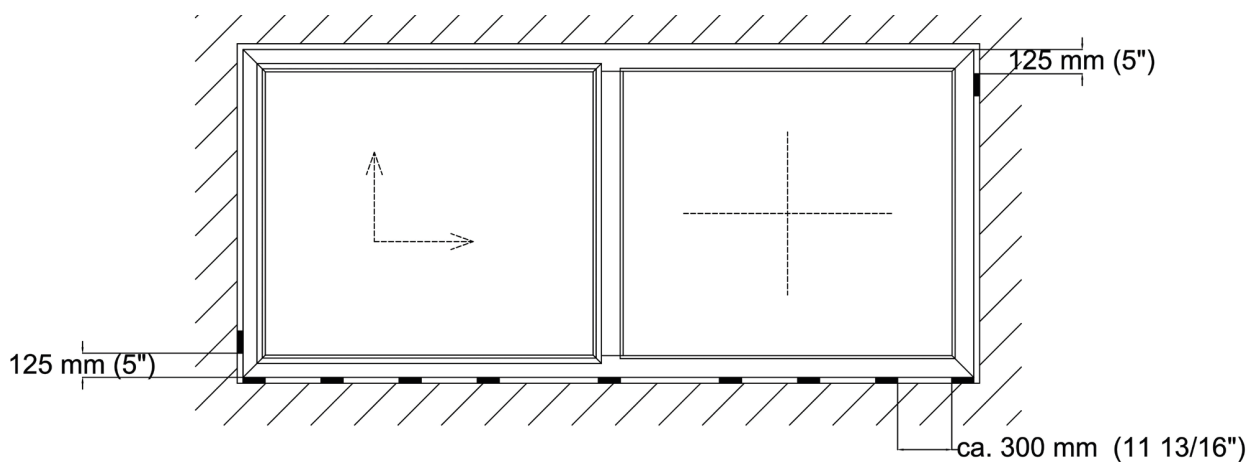

Anchor Door Sills

The 20mm thermally broken aluminum threshold and the 56mm high performance doors sills cannot be fastened with anchor straps. The following steps allow them to be effectively anchored. Note that these steps are performed after ensuring the sill is integrated with the building's water control layer.

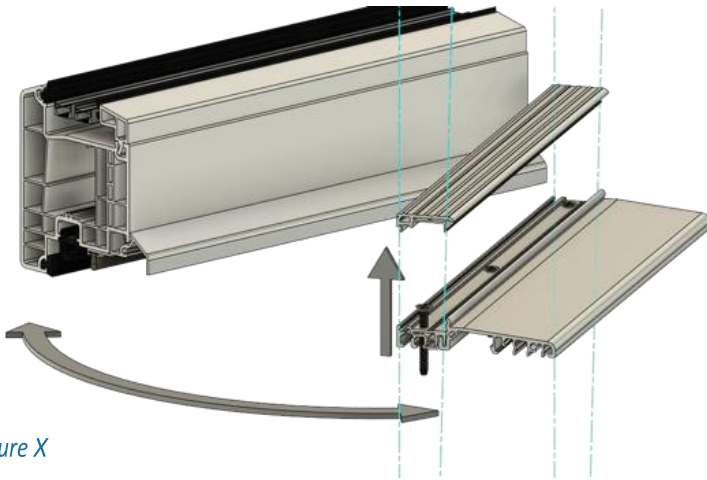

Figure X

20mm Thermally Broken Aluminum Threshold

1. Ensure there is no bow in the sill in either plane.
2. Remove the threshold cover.
3. Use quality #8 flat head screws (such as Spax or GRK) with a minimum length of 1" (25mm) (longer if necessary). The screws will go through the middle of the space covered by the threshold cover. Predrill holes and use suitable screws if going into concrete.
4. Install screws approximately 1" (25mm) from each jamb. On French doors, install screws 1" (25mm) on both sides of the center lock strike on the sill.
5. Install additional screws to ensure the screws are spaced no more than 18" (~500mm) apart. If there is any gap between where a screw is placed and the floor, ensure to shim under the sill to prevent bowing.
6. Reinstall the threshold cover.

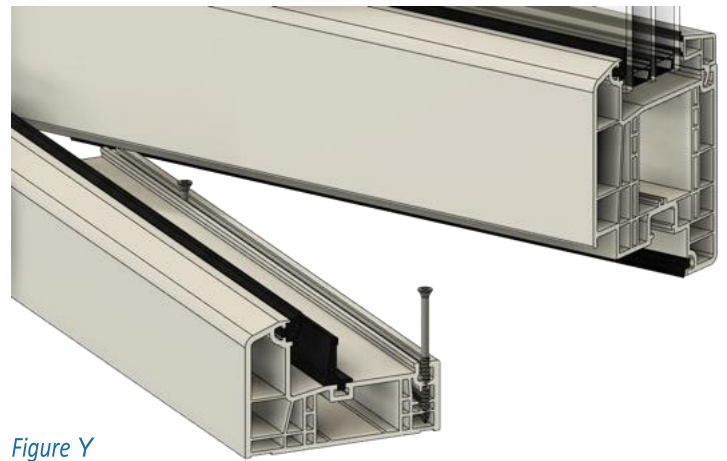

Figure Y

56mm High Performance Sill

1. Ensure there is no bow in the sill in either plane.
2. Use quality #8 trim head screws (such as GRK) with a minimum length of 1 ½" (38mm) (longer if necessary). The screws will go through the groove in the sill. Predrill holes and use suitable screws if going into concrete.
3. Install screws approximately 1" (25mm) from each jamb. On French doors, install screws 1" (25mm) on both sides of the center lock strike on the sill.
4. Install additional screws to ensure the screws are spaced no more than 18" (~500mm) apart. If there is any gap between where a screw is placed and the floor, ensure to shim under the sill to prevent bowing.

Reinstall Sashes and Hinge-side Drywall Return

Tilt & Turn Sashes

1. Remove the upper hinge cover on the frame and pull the hinge pin down until a click is heard.
2. Ensure the lower hinge on the sash is clear of dirt and debris.
3. Ensure the stay arm on the top of the sash is parallel to the sash and fully seated.
4. Tilt the lower hinge pin on the frame outwards approximately 30°.
5. Lift the sash onto the lower hinge pin.
6. Push the top of the sash in so the hinge side of the sash is parallel to the frame and the hinge portion of the stay arm is sitting in the upper hinge of the frame.
7. Push the upper hinge pin in through the upper hinge assembly until a click is heard.
8. Reinstall the upper hinge cover.

Entry Door Sashes

Rehanging entry door sashes is best done with three people, two to lift the sash, one to guide the hinges together.

1. Lift the sash onto the frame turned at approximately 90°.
2. Guide the sash portion of the hinge onto the pins on the frame side of the hinge.

Entry Door Hinge-side Drywall Return

Once the entry door is in place, shim and reinstall the drywall return on the hinge-side.

Function Check

Check tilt & turn sashes for locking, tilting & turning.

Check entry door sashes for locking.

Troubleshooting

All windows and doors are checked for proper operation at the factory before shipping. Therefore, if a tilt & turn or entry door sash is not functioning properly, it is highly probable that there is a problem with the installation.

Before any attempt to adjust the hinges is made, do the following:

1. Ensure the head and sill are level.
2. Ensure the jambs are plumb.
3. Ensure there is no bow in any frame member by measuring the width and height of the frame in multiple locations.
4. Ensure the sash was not bowed by improper lifting or storage. If it was, the bow can be removed as shown in Figure 19.
5. Once proper plumb, level and square have been checked minor hinge adjustments can be made as necessary according to the hardware instructions.

Install Screens

It is best if screens are installed after all exterior finishing work has been completed to avoid damage. Your sales representative can supply a video of screen installation upon request.

Install a screen clip approximately 2" from each corner on the screen.

Snap the screen into the frame.



**Access Window and Door
Design Centre Ltd.**

565 Cargill Road
Winkler, MB R6W0K4

Office: +1 (800) 249 1216

Fax: +1 (204) 480 4863

Email: info@accesswd.ca